

IF YOUR DECK IS LESS THAN 0.6 METRES (2 FEET) FROM THE GROUND, YOU DO NOT REQUIRE A BUILDING PERMIT

Application Procedure

Should you require a building permit please supply the following information (two copies of each):

1. A Site Plan showing:
 - lot and house;
 - deck size and location of deck steps;
 - existing side and front yard measurements (from property line); and
 - side yard and rear yard measurement to new deck.
2. A Drawing showing:
 - size and height of deck;
 - size of beam and spacing of posts;
 - size and spacing of joists;
 - material used for decking;
 - guardrail and handrail details;
 - for covered deck, if applicable, roofing material and supports; and depth and type of foundation.

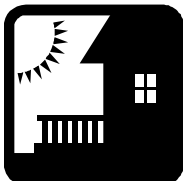

Electrical and gas meter and/or gas shut off cannot be located under a deck.

Examples

SITE PLAN

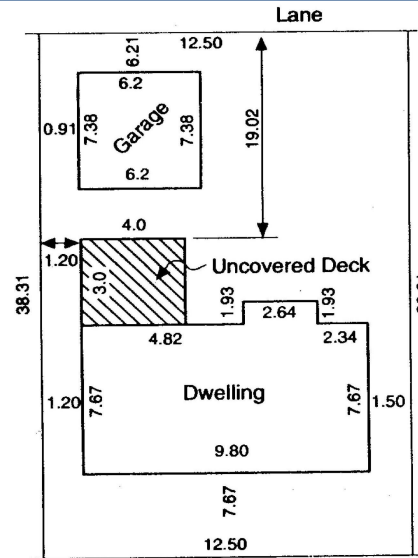

DRAWING (SCALED CROSS-SECTION)

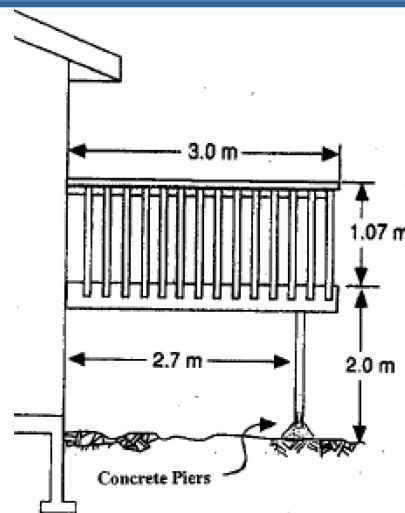

GENERAL BC BUILDING CODE REGULATIONS

If your deck is more than 0.6 m above grade, then you must apply for a building permit which is subject to the BC Building Code. The following is general information about construction and is for general use. For specific information, please contact a Peace River Regional District office.

Decks may be supported on patio blocks or deck piers on grade. Covered decks must be supported on pad footings (min. 1.2 m, 4 ft. below grade) or a perimeter strip footing 4 ft. below grade or pilings with stamped engineered design. Roof joists, floor joists and beams are to conform to the current BC Building Code.

Stairs are to have: Rise: max 8 in., min 5 in.; Run: max 14 in., min 8 in.; Tread: max 14 in.; Stair Width: min. 34 in., min depth: 9 in. All steps in each flight are to have uniform rise and run.

Stair Construction:

Exterior wood steps shall not be in direct contact with the ground unless suitably treated with a wood preservative.

*Stair stringers supporting treads are to be a min. 2 in. x 10 in.; spaced max. 36 in. apart.

Handrails / Guards:

Exterior stairs over 3 risers require a handrail mounted between 34 in. and 38 in. above the front edge of stair treads. Stairs greater than 44 in. wide require two handrails. Min. 36 in. high guards are required for steps, landings, porches and balconies where the difference in elevation to adjacent surfaces is over 2 ft. Where the difference in elevation is over 6 ft., min. height of guard is 42 in. Guards are to consist of all vertical spindles max. 4 in. apart and be designed so that no member, attachment or opening located between 4 in. and 35 in. above the deck will facilitate climbing. Seats are not to be incorporated into a required guardrail.

*Stringers: Side support for stair treads and risers.

Inspections required . . .

Two Deck Permit inspections are required; please the Peace River Regional District Office to schedule:

Dawson Creek: 250-784-3212

For Development or Building Permits, contact the Peace River Regional District Planning Department

For Electrical and Gas permits contact:

BC Safety Authority
886-566-7233

Other Contact Numbers:

BC One Call (call before you dig) 800-474-6886
(or website: www.bconecall.bc.ca)

BC Housing, Licensing & Consumer Services:
800-407-7757

BC Safety Authority: 886-566-7233

Ministry of Transportation: 800-661-8773

or Service BC (all ministries) 800-663-7867



PEACE RIVER REGIONAL DISTRICT
www.prrd.bc.ca

Hours of Operation
Monday to Friday
8:30 a.m. to 4:30 p.m.
(closed 12 p.m. to 1 p.m.)

[1981 Alaska Avenue]
Box 810,
Dawson Creek, BC
V1G 4H8

prrd.dc@prrd.bc.ca

Telephone: 250-784-3200

Toll-free: 800-670-7773

or

9505 100 Street
Fort St. John, BC
V1J 4M4

prrd.fsj@prrd.bc.ca

Telephone: 250-785-8084

NOTE:

This is a general guide.
Additional information may be required.

Peace River Regional District

DECKS



Do you require a deck permit?



Telephone: 250-784-3200